

#### COMMENTS:

Mounted CSO-V22005C hard Chassy, Front spool axle CSO-18053H, Membranes Hard CSO-18077H, ECS 44mm (Front) CSO-20195, Rear D 2.5 Degree Toe-in CSO-V22028BD

Date: January 6, 2014

Driver: Marco Puleo

EVENT: Befana Race 13.5 Stock

Track/Tation: Scandiano - Italy

#### FRONT

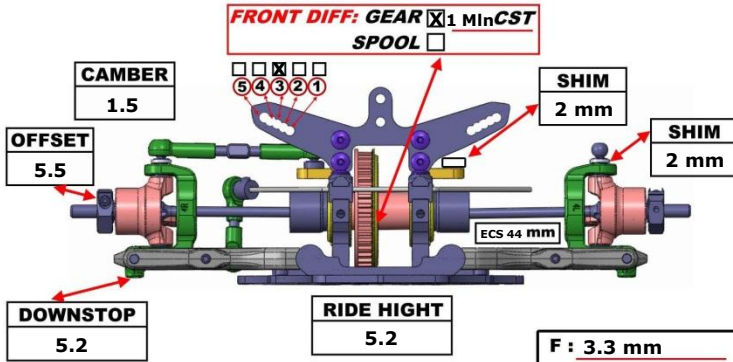

#### REAR

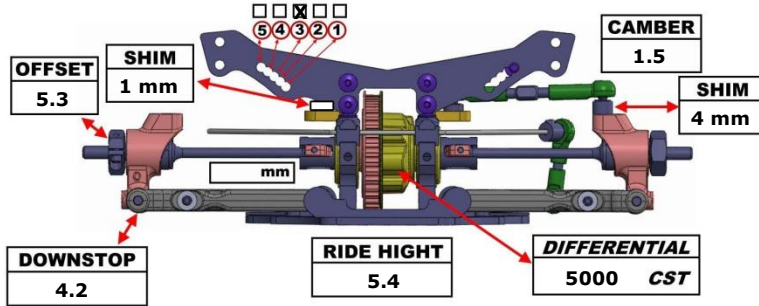

Track Info:  Indoor  Outdoor  CARPET  ASPHALT

Temp: Track 13° / Weather Cloudy/Sunny

Track Type:  Technical /  Mixed /  Fast

Track Traction:  Low /  Medium /  High

BODY: Nazda 2 WING:

MOTOR: 13.5T LRP TIMING: No

ESC: Flow LRP BATTERY: 7200 LRP

TIRES: F Ride 30 / R Ride 30

DIAMETER: F / R

INSERS: F / R

ADDITIVE: F Hudy / R Hudy

TRACK COMMENTS:



	FRONT	REAR
OIL	350	400
SPRING	RSD Gold	RSD Silver
HOLES DIAMETER	1.1	1.1
PRELOAD		
FOAM INSERTS		
REBOUN	0	0
LENGTH	4.2	4.2
O-RING ON SHAT		

SUSPENSION BLOCK (A)	SUSPENSION BLOCK (B)	CHASSIS	SUSPENSION BLOCK (C)	SUSPENSION BLOCK (D)
0	2.5	Hard	2.5	2.5
ROLLING CENTER SHIM	ROLLING CENTER SHIM	TOP DESK	ROLLING CENTER SHIM	ROLLING CENTER SHIM
No	0.5 mm	2 mm	No	No

